



TRANSFLUID[®]

industrial & marine

TRANSFLUID



drive with us

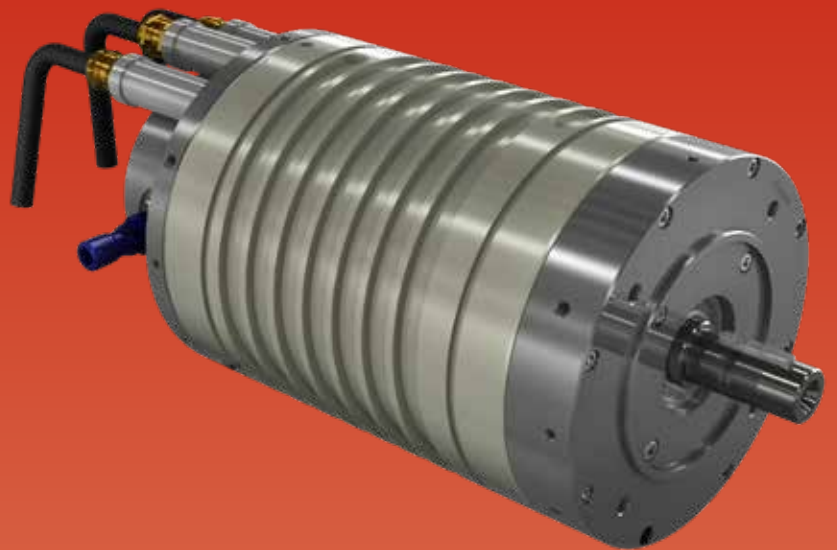

**PERMANENT MAGNETS
ELECTRIC MACHINES**

PERMANENT MAGNETS ELECTRIC MACHINES

1. DESCRIPTION

TRANSFLUID manufactures three-phase, Permanent Magnet Synchronous Machines (PMSM) with natural convection air cooling. This solution ensures high efficiency with a limited weight and size. The electric machine are controlled by a Motor Controller (Frequency Drive) that allows to work both as a motor and as a

generator. The perfect integration of the range of electric machines with controllers allows for a compact system installation, as well as makes management easy and effective during any operation stage.

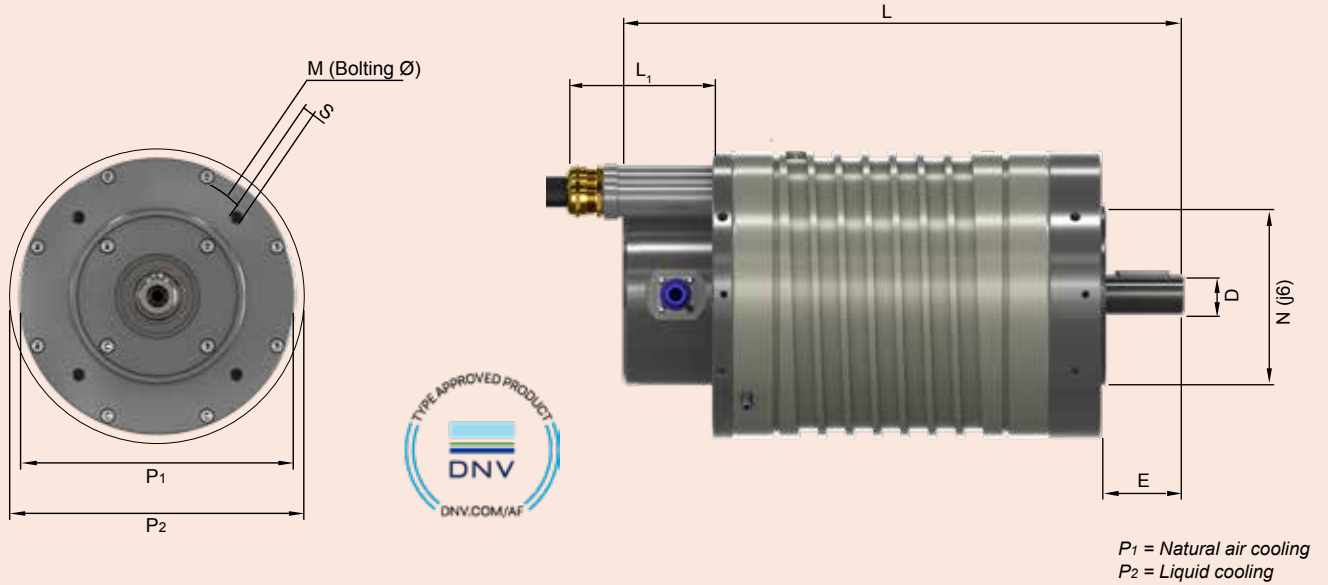

Tab. PERFORMANCES

TF - EM	MOTOR kW (hp)	MOTOR PEAK kW (hp)	GENERATOR kW (hp)	NOMINAL VOLTAGE Vrms	NOMINAL TORQUE Nm (lb-ft)	NOMINAL CURRENT A ~	BATTERY Vdc	MOTOR Adc	GENERATOR Adc
180 - 4 *	4 (5)	5 (7)	4 (5)	62	13 (10)	41	96	45	40
180 - 8 *	8 (11)	10.5 (14)	7 (10)	60	25 (18)	85	96	89	84
180 - 12 *	12 (16)	16 (21)	10 (14)	60	38 (28)	142	96	133	124
220 - 20 *	20 (27)	25 (34)	17 (23)	68	64 (47)	175	96	221	185
220 - 35 *	35 (48)	45 (60)	33 (45)	159	111 (82)	137	288	128	119
300 - 50 *	50 (68)	65 (88)	49 (67)	178	159 (117)	167	288	184	177
300 - 75 *	75 (100)	100 (134)	72 (98)	242	239 (176)	242	288	278	266
300 - 100 *	100 (136)	130 (177)	97 (132)	252	318 (235)	322	384	273	251
375 - 200 **	200 (268)	260 (349)	190 (255)	257	830 (612)	2x250	384	525	493

* 3000 rpm

** 2300 rpm (power supply with double inverter)

Tab. DIMENSIONS

TF - EM	WEIGHT kg (lb)	D mm (inch)	E mm (inch)	L mm (inch)	M mm (inch)	N mm (inch)	P ₁ mm (inch)	P ₂ mm (inch)	S
180 - 4	19 (42)	28 (1.1) j6	60 (2.4)	328 (12.9)	≈165 (6.5)	130 (5.1)	205 (8.1)	240 (9.4)	4xM10
180 - 8	25 (55)	28 (1.1) j6	60 (2.4)	368 (14.5)	≈165 (6.5)	130 (5.1)	205 (8.1)	240 (9.4)	4xM10
180 - 12	35 (76)	28 (1.1) j6	60 (2.4)	408 (16.1)	≈165 (6.5)	180 (7.1)	205 (8.1)	240 (9.4)	4xM10
220 - 20	58 (128)	38 (1.5) k6	80 3.1	460 (18.1)	≈215 (8.5)	180 (7.1)	243 (9.6)	277 (10.9)	8xM12
220 - 35	80 (175)	38 (1.5) k6	80 3.1	543 (21.4)	≈215 (8.5)	180 (7.1)	243 (9.6)	277 (10.9)	8xM12
300 - 50	135 (295)	55 (2.2) m6	110 (4.3)	602 (23.7)	≈265 (10.4)	230 (9.1)	332 (13.1)	360 (14.2)	8xM12
300 - 75	185 (404)	55 (2.2) m6	110 (4.3)	702 (27.6)	≈265 (10.4)	230 (9.1)	332 (13.1)	360 (14.2)	8xM12
300 - 100●	195 (425)	55 (2.2) m6	110 (4.3)	702 (27.6)	≈265 (10.4)	230 (9.1)	332 (13.1)	360 (14.2)	8xM12
375 - 200●	410 (1080)	75 (2.9) m6	140 (5.5)	911 (36)	≈500 (19.6)	450 (17.7)	-	450 (17.7)	8xM17

● Only water cooled

Special E.Machines on request

2. CHARACTERISTIC

The structural characteristics of electric machines are optimized for any use up to 3000 rpm. The systems are convection cooled, making an easy on-board installation. This allows you to use the power in a progressive manner throughout its whole range of speed. The torque curve, which characterizes these types of motor at low speed, can be two times the nominal rating which is extremely useful for vehicle acceleration. In the range of medium speed, up to about 1500 rpm, the torque delivered can be twice as much as the nominal rating for a limited time. In marine applications, this is particularly useful for low vessel speed maneuvering.

All electric machines are equipped with thermal sensor KTY 84-130 and can be equipped with sin/cos magnetic encoder, resolver 2 poles 7V 10kHz and incremental encoders from 500 to 4096 ppr.

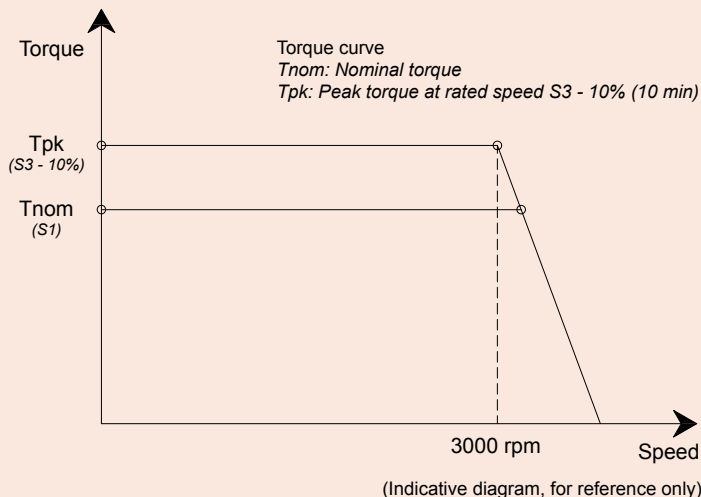

3. DEFINITION OF POWER RATINGS FOR NATURAL CONVECTION AIR-COOLED MACHINES

Rating power and torque listed in the performance table, are referred to continuous duty **S1** at rated speed and ambient temperature of 40°C at 1000m a.s.l.

If motors work at ambient temperature more than 40°C or at altitude above 1000 m a.s.l., then derating coefficients **K₁** and **K₂** should be applied (see table below).

Ambient temperature	40°C	45°C	50°C	55°C	60°C
Correction factor K₁	1	1.06	1.13	1.22	1.34
Altitude a.m.s.l. up to	1000m	2000m	3000m	4000m	5000m
Correction factor K₂	1	1.07	1.16	1.27	1.55

In case of high ambient temperature and in order to avoid electric machine derating, forced air-cooling kit is also available.

Blowing fan
12 Vdc or 24 Vdc

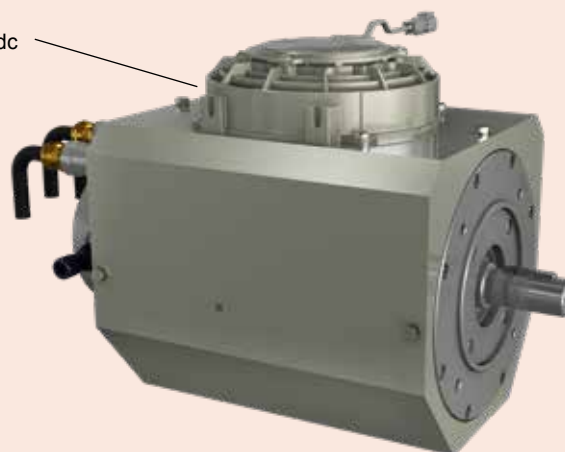

Liquid out

Liquid in

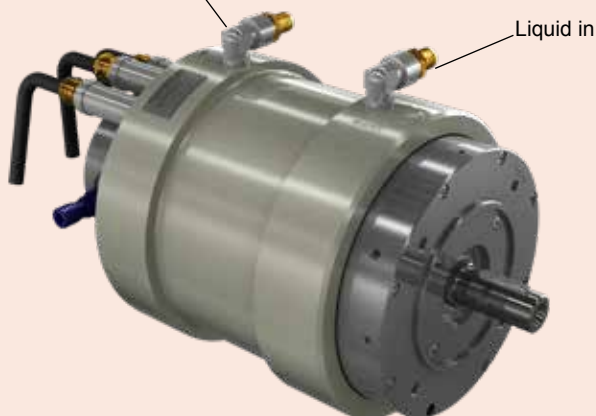

Depending on the installation condition, liquid cooling kit is also available to avoid electric machine derating.

Technical features, dimensions and any other data are not binding. Transfluid S.p.A. reserves the right to change them without notice

ELECTRIC PROPULSION SYSTEM

Up to 130 kW
with single, two and three speed transmission.
Industrial and marine applications

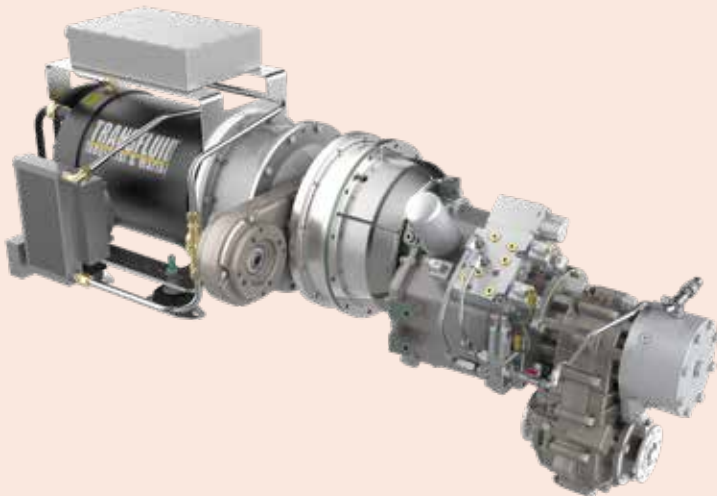

HYBRID MODULE

Combustion engine
Up to 1230 kW
and up to 200 kW electric
Industrial and marine applications

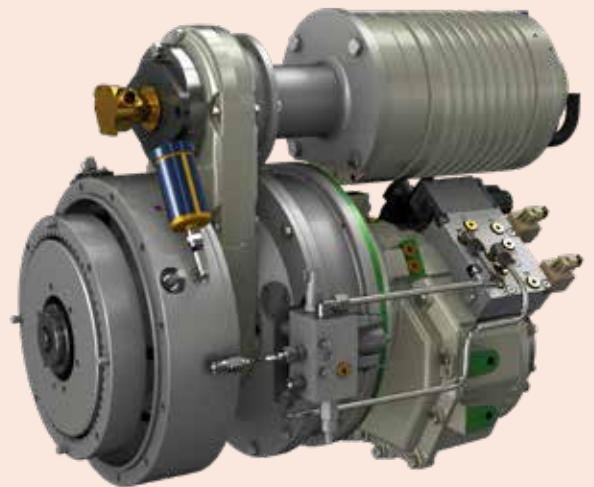

CHINA

TRANSFLUID BEIJING
TRADE CO. LTD Beijing
Ph.: +86.10.60442301-2
tbtcinfo@transfluid.cn

U.S.A.

TRANSFLUID LLC
Auburn, GA 30011
Ph.: +1.770-822-1777
tfusa@transfluid.us

FRANCE

TRANSFLUID s.a.r.l.
38110 Rochetoirin
Ph.: +33.9.75635310
tffrance@transfluid.eu

U.K.

TRANSFLUID UK LTD
London
Ph. +44.7445501066
marine@transfluid.co.uk

THE NETHERLANDS

TRANSFLUID NORTH EUROPE B.V.
NL-3992 AK, Houten
Ph. +31 (0)85 4868530
info@bellmarine.nl

LOCAL DISTRIBUTOR

Global webs site: www.transfluid.eu
E-commerce web site: www.buy-transfluid.com